



ORIGINAL ARTICLE

Numerical Study on the Effect of Combined Buildings on Pollution Emission with using FLUENT software

Ali Hooshmand Aini

Department of Civil Engineering, Roudbar Branch, Islamic Azad University, Roudbar, Iran

Email: Ali_Hooshmand1983@yahoo.com

ABSTRACT

Distribution of pollutants in the air is a complex issue because of the complexity of air movement in the atmosphere and its effective factors. So by chimney design, it is necessary to consider environmental pollution issues in addition to thermodynamic and structural calculations. This paper is a numerical study on the effect of combined buildings on the pollution emissions using CFD. For this purpose, the geometric modelling is done using software GAMBIT and the model is analyzed by software FLUENT. The results are displayed by speed contours in directions X, Y, and the pattern of flow.

Keywords: Chimney, Pollution Emission, GAMBIT, Computational Fluid Dynamics, FLUENT.

Received 20.03.2014

Revised 12.04.2014

Accepted 08.06. 2014

INTRODUCTION

Unbridled growth and development of cities due to an increase in the growth of city inhabitants cause the dispersion in the structure of the city. This issue causes damaging effects on environment. Air pollution as one of the most important factors affecting urban environment has caused problems in urban areas. It threatens not only the inhabitants of the cities, but the environment itself. Hence, planners and urban designers take the urban planning and sustainable development into consideration to reduce the consequences of the unprecedented growth of the cities. The sustainable development and smart growth of cities by providing the principles and strategies want to reduce the negative effects of unreasonably urban distribution and to determine the best location for development. Lack of environmental awareness is the problem of the recent century and the air pollution is part of it. Geographical location, type of land use, climate and human activities are aggravating factors of air pollution. Nowadays, with the development of cities, industries and expansion of factories, industrial workshops and vehicles all over the world, the human environment strongly affected by the fragmentation, so that the weather in some parts of the world have been threatened and even hazardous in some areas (Figure 1 and 2).



Figure 1. a) Milad Tower in air pollution b) Cairo, the most polluted city in the world

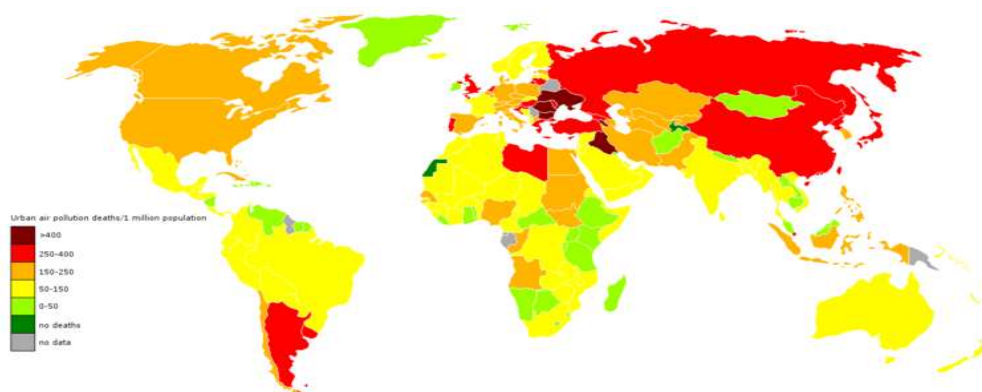

Figure 2. Distribution of deaths caused by pollution in 2004

Countries use various methods for the prevention of air pollution. Some of them imposed strict controls and the other countries ignore the issue. In table 1, we can see countries that consume the maximum amount of carbon dioxide and in table 2 we see countries that have the most per capita consumption of the carbon dioxide.

Table 1. List of countries that produce the greatest amount of carbon dioxide

Countries with the highest CO ₂ emissions			
Country	Carbon dioxide emissions per year (10 ⁶ Tons) (2006)	Percentage of global total	Avg. emission per km ² of its land (tons)
China	6,103	21.5%	636
United States	5,752	20.2%	597
Russia	1,564	5.5%	91
India	1,510	5.3%	459
Japan	1,293	4.6%	3421
Germany	805	2.8%	2254
United Kingdom	568	2.0%	2338
Canada	544	1.9%	54
South Korea	475	1.7%	4758
Italy	474	1.7%	1573

Table 2. List of countries that have the highest per-capita production of carbon dioxide

Countries with the highest per capita CO ₂ emissions	
Country	Carbon dioxide emissions per year (Tons per person) (2006)
Qatar	56.2
United Arab Emirates	32.8
Kuwait	31.2
Bahrain	28.8
Trinidad and Tobago	25.3
Luxembourg	24.5
Netherlands Antilles	22.8
Aruba	22.3
United States	19
Australia	18.1

One way for pollution reduction is to establish standards or to limit materials emission at an acceptable level. Historical records of air pollution in Iran go back to the year 1350; the same year of the first Symposium on Air Pollution held by national oil company [2]. The important issue is that the problem of air pollution since that year is not solved; the numbers of the days when the air pollution index was excessive during the last year has been increased. Now, 7 large cities are involved with the issue of pollution, 7 other cities are going to involve with the issue of pollution and more than 60 percent of air pollution in big cities is related to the most of private and public transport vehicles and the rest is related to domestic resources, industries and factories. Air pollution and other environmental pollution affect

humans and other living things. So the better understanding of these problems and their solutions are one of the necessities of our society [10]. Air pollutants are ozone and nitrogen dioxide, sulfur dioxide, dust particles, lead and carbon monoxide. All air pollutants except carbon monoxide and lead influence on respiratory tract and increase respiratory symptoms in patients or cause other harmful effects on health. Although lead and carbon monoxide do not affect the respiratory function, they have adverse effects on other organs. Lead causes behavioral disorders in children and high blood pressure in adults [3]. Carbon monoxide affects the cardiovascular system and increases cardiovascular mortality [7]. Nowadays, air pollution is known as a very important problem at the national and international levels. Scientific findings regarding the effects of air pollution on health is increasing, and numerous studies have shown the effects of air pollution. Infants and children are among the most sensitive individuals to air pollutants.

MATERIALS AND METHODS

Flow Pattern around Building:

The pattern of air flow in the direction of the wind around buildings is shown in the figure 3. Two-third of the height from the floor is called the inertia spot; from that point, air flows upwards and passes out of the roof of the building. Below this point, the air flows downwards that formed vortex in front of the building and finally passes around the building. In the back of wind flow is the detachment more and the vortex can be seen again (Figure 3). Air flow speed increases at the corners of the building, whether vertical or horizontal. Putting the buildings together and structure appearance also cause turbulent flows and complex aerodynamic problems; these factors play an important role in the structural analysis [11].

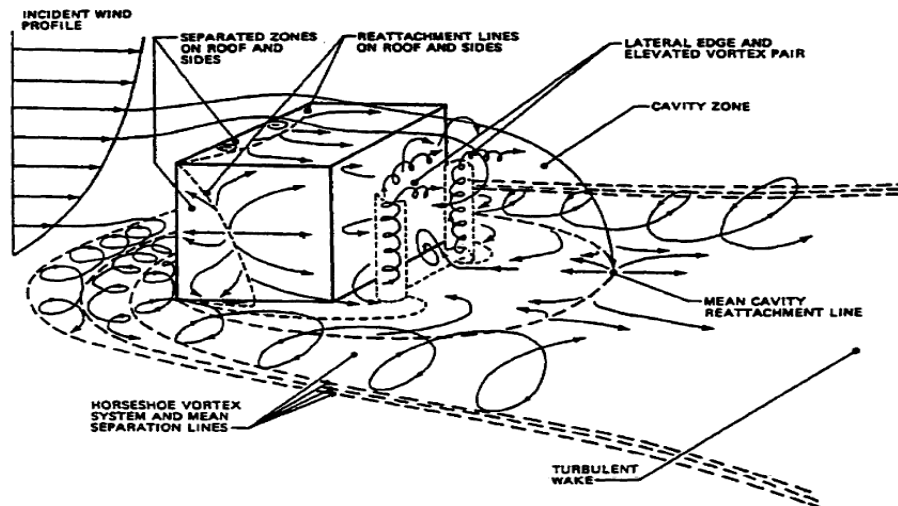

Figure 3. The flow pattern around the building with cutting edge Hosker (1979)

Distribution of pollutants in the air due to the complexity of air movement in the atmosphere and affecting factors is a complex issue. This issue is very important in the area of troposphere especially for human. One of the most complex situations to predict the distribution of pollutants in the atmosphere is that the buildings and facilities are close to each other and topographic conditions are not the same. The output of the industrial Chimney is one of the major sources of air pollutant (Figure 4). The research results have shown effective parameters, including the distance between the building and the chimney, the ratio of their height, as well as the direction and speed of the wind, are effected the distribution of pollutant concentration of the chimney [8]. In Figure 5, the flow pattern of the chimney structure and in figure 6 the flow pattern in the structure of the complex geometry is shown.

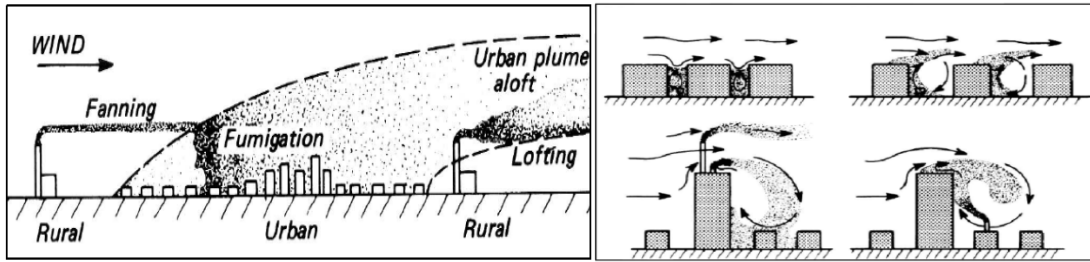

Figure 4. Effect of Chimneys on urban air quality Oke (1987) [1]

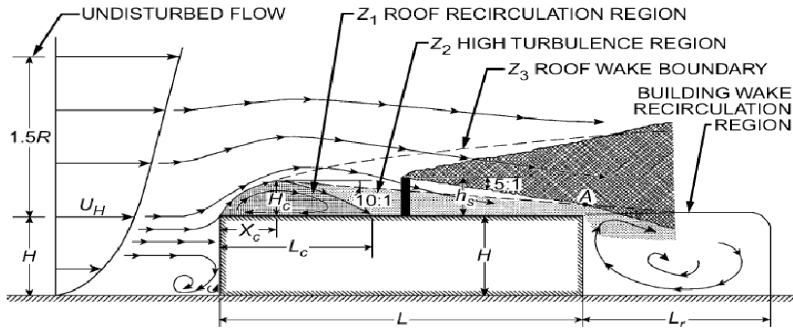

Figure 5. The flow pattern around the building with chimney Wilson (1979)

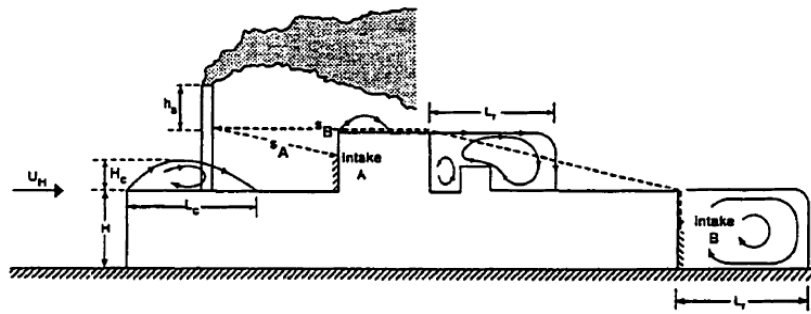

Figure 6. The flow pattern around the building of complex geometry (ASHRAE Handbook-1997 Fundamentals15.2) [13]

In the design of the chimney, effective chimney height (H) is the total height of the chimney structure (h_s) and smoke height (Δh). The height of smoke is the distance between the center of symmetry of smoke and the upper or lower edge of smoke (Figure 7). The height depends on several factors, including the characteristics of smoke and gas.

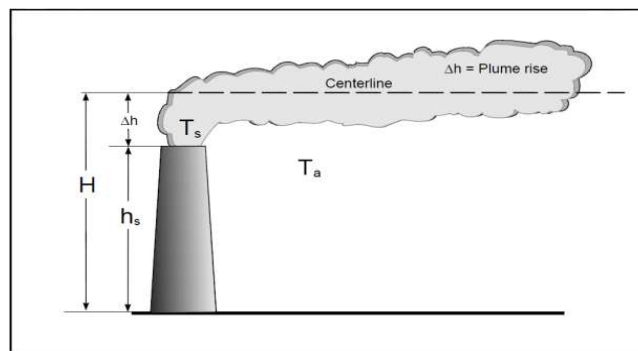

Figure 7. Effective chimney height

In the design of thermal power station projects, it is necessary to consider environmental pollution issues in addition to thermodynamic and structural calculations. Nowadays, modeling is inevitable to facilitate the study of various natural phenomena [9]. To predict the pollution emission around buildings, different models are provided; such a Gauss model in which a source point (Figure 8) is intended. In this figure, the letter z shows the vertical direction and the letter x shows the movement of smoke front along the

downstream; if we check the smoke mass at different times we'll see smoke mass is inconsistent (Figure 8).

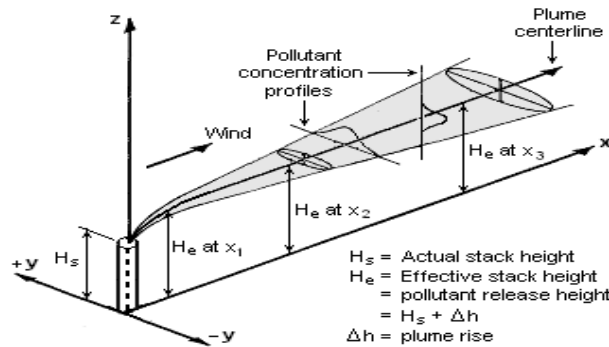

Figure 8. Smoke mass distribution of the Gauss distribution

The following equation is the Gauss equation of the pollution emissions (Figure 9):

$$\frac{x U_r H^2}{Q} = \frac{\left[\exp\left(-\frac{1}{2\sigma_y^2}\right) \right] \left\{ \exp\left(-\frac{1}{2}\left[\frac{z-H_s}{\sigma_z}\right]^2\right) \right\} + \exp\left[-\frac{1}{2}\left[\frac{z+H_s}{\sigma_z}\right]^2\right] \right\}}{2\pi\sigma_z\sigma_y/H^2} \quad (1)$$

In this equation: x=Pollution concentration (g/m³), Ur=Average wind speed affecting smoke (m/s²), Q=Emission rate (g/s²), H=height of the building (m), Hs=Height of smoke symmetry center (m), Yσ=Horizontal dispersion coefficient [6].

NUMERICAL MODELLING

There are three ways to solve problems regarding the fluid mechanics including experimental, analytical and numerical methods. Progress of numerical methods in various sciences in recent decades has been remarkable. Nowadays, most researcher's use of numerical methods due to the high costs of empirical methods and the weakness of analytical techniques in solving engineering problems. The geometry of the structure was created in Gambit software using the existing map to achieve the effect of buildings composition on air pollution emissions (Figure 9). We use speed input and pressure output (Figure 9). Then we moved the geometry to the FLUENT software.

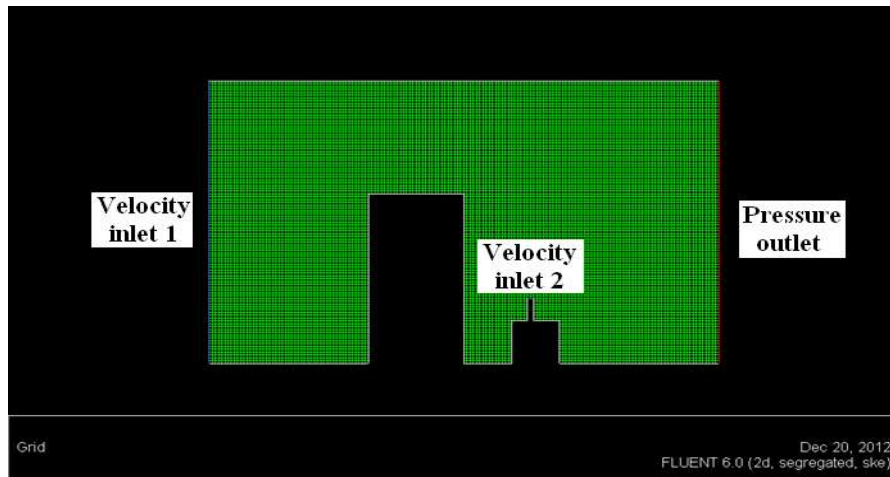

Figure 9. Model geometry, mesh and boundary conditions applied in the model.

All flows that are considered in practical engineering, ranging from simple or very complex three-dimensional are above Reynolds number. By low Reynolds number, the flow is slowly. At high Reynolds numbers, the turbulent flow can be seen. In simple cases, the continuity equation (Eq. 2) and the Navier-Stokes can be solved by numerical CFD methods such as finite volume method [12].

$$\frac{\partial \rho}{\partial t} + \frac{\partial}{\partial x_i}(\rho u_i) = 0 \quad (2)$$

In this paper, we have chosen k-ε as the turbulence model. In this model, two transport equations are solved - one for the turbulent kinetic energy k and the other for turbulent kinetic energy dissipation rate

ε . By the standard k- ε model, the transport equations (3) and (4) are used for ε and k in the Fluent software [4].

$$\frac{\partial}{\partial t}(\rho k) + \frac{\partial}{\partial x_i}(\rho k u_i) = \frac{\partial}{\partial x_i} \left[\left(\alpha + \frac{\alpha_t}{\sigma_k} \right) \frac{\partial}{\partial x_j} \right] + G_k + G_b \tag{3}$$

$$\frac{\partial}{\partial t}(\rho \varepsilon) + \frac{\partial}{\partial x_i}(\rho \varepsilon u_i) = \frac{\partial}{\partial x_i} \left[\left(\alpha + \frac{\alpha_t}{\sigma_k} \right) \frac{\partial \varepsilon}{\partial x_j} \right] + C_{1s} \frac{\varepsilon}{k} (G_k + C_{3s} G_b) - C_{2s} \rho \frac{\varepsilon^2}{k} \tag{4}$$

$$k = \frac{1}{2} (\overline{u'^2} + \overline{v'^2} + \overline{w'^2}) \tag{5}$$

K=kinetic energy (per unit mass) relating to the turbulent, α =Turbulent viscosity. The equations include five fixed adjustable values:

$$\sigma_k = 1.0, C_\alpha = 0.09, C_{1\varepsilon} = 1.44, C_{2\varepsilon} = 1.44, \sigma_\varepsilon = 1.0$$

G_k =turbulent kinetic energy term is medium due to velocity gradient, G_b =Turbulent kinetic energy term is due to the buoyancy force [5].

RESULTS AND DISCUSSION

The results of the problem solution have been shown in figures 10 to 14. According to the results and figures, it can be concluded that the maximum amount of velocity and velocity in the direction of x are occurred after the building and in the upper part of the model regarding the wind (Figure 10 and 11).

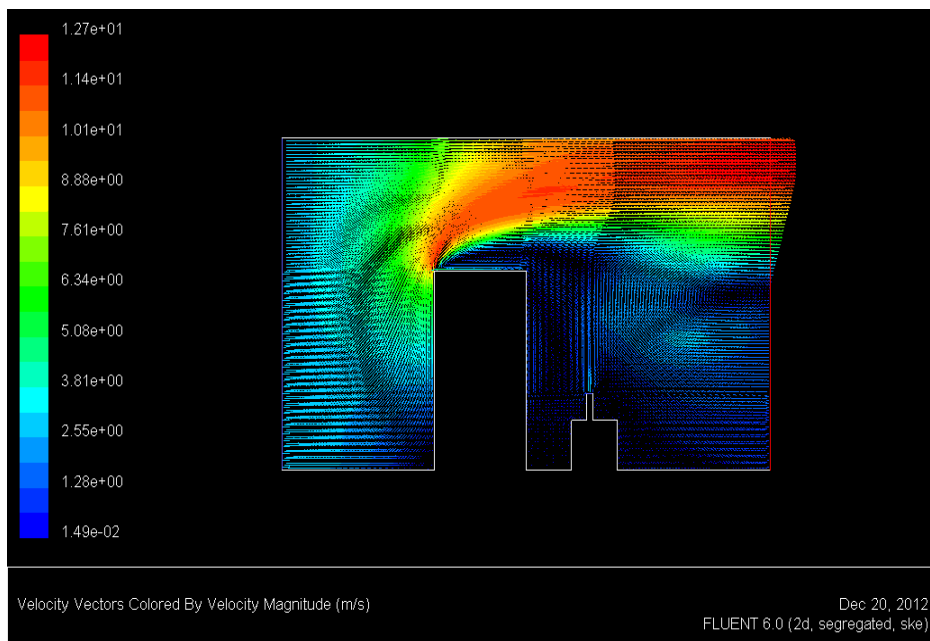

Figure 10. Velocity vectors in the model.

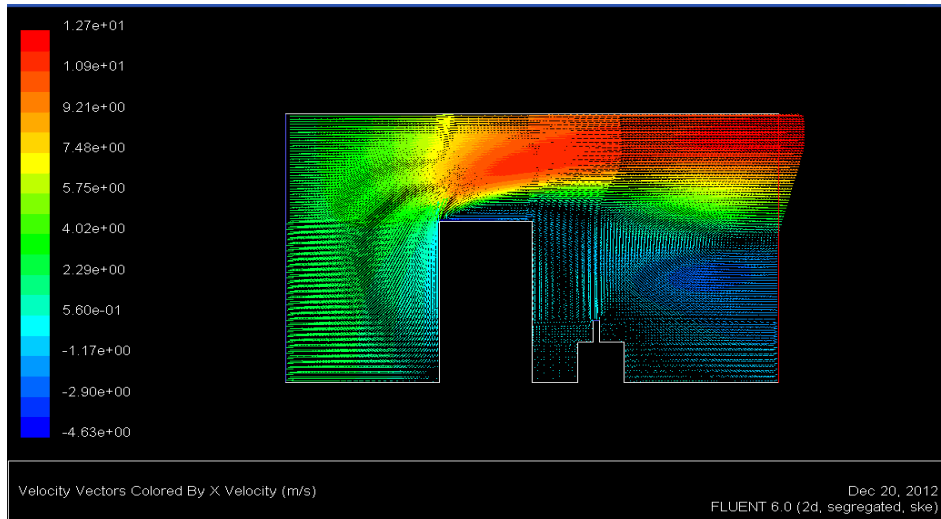

Figure 11. Velocity vectors in X direction

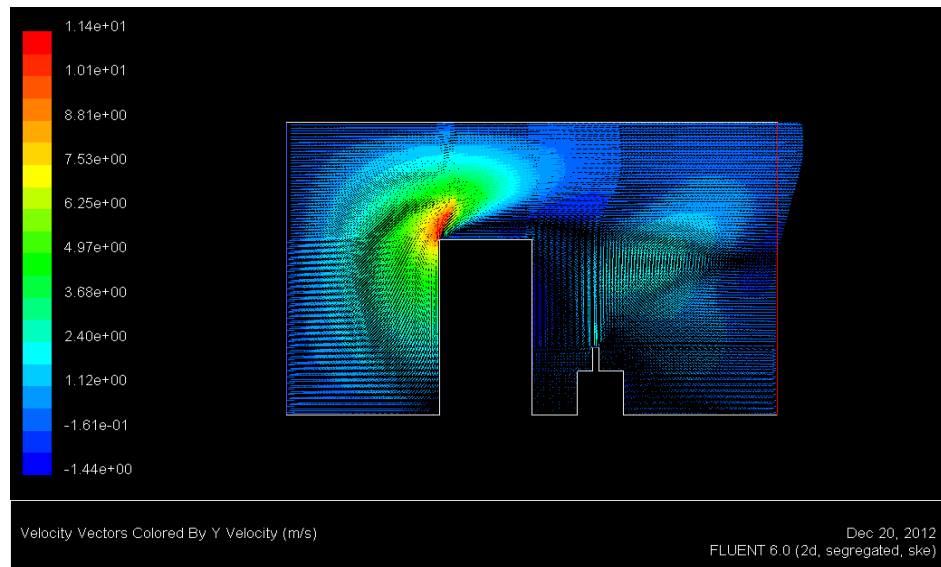

Figure 12. Velocity vectors in Y direction

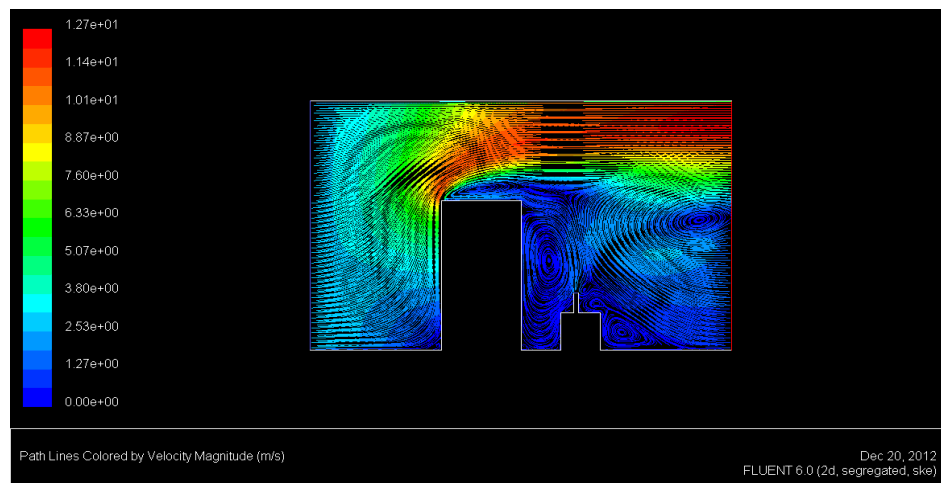

Figure 13. Flow patterns in Models

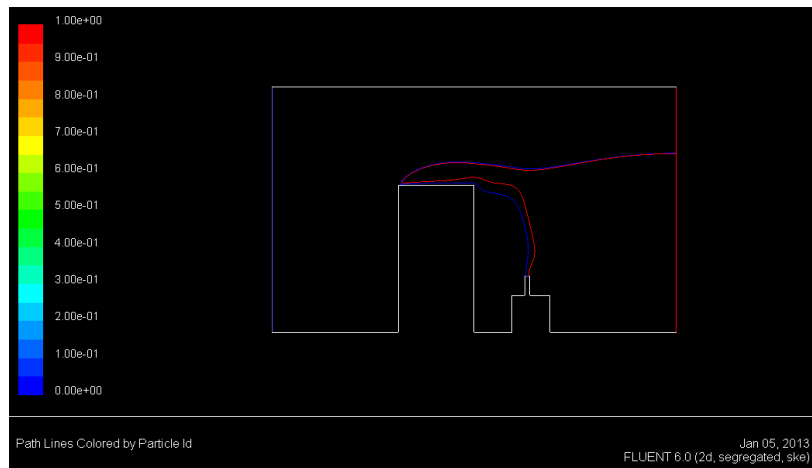

Figure 14. Flow pattern of smoke from the chimney

As we can see in Figure 12, the maximum velocity in the direction of Y has happened at the top of the building. According to the flow pattern and vortex (Figure 13) as well as the flow pattern of the chimney (Figure 14), we can conclude that the smoke from the chimney is distributed completely around the building and in the environment due to the wind. As we observed, the pattern of flow resulting from the analysis matches the pattern of the flow provided by Oke (1987) (Figure 4). According to the values and the figures, it can be concluded that FLUENT software can be considered as capable regarding the modeling of smoke flow arising from the chimneys and by using this software, we can obtain the parameters of flow.

REFERENCES

1. Bahreini, Seyed Hossein, Arefi, Mahyar, Barkpor Naser, Hasan Khoshpor, (1993), Applications of Air Pollution Meteorology Studies in Urban Design (Case Study: Tehran), Ecology, No.18.
2. Bayat, Reza, (2003), Portion sources of air pollution in Tehran, Ms.c thesis, Departement of Civil Engineering- Sharif University of Technology.
3. Pishkar, Ahmadsreza, Kamal, Khalili, (2004), Effects of ambient air pollution on infant and child health, First Conference of air pollution and its effects on health.
4. Soltani, Majid, Rahimiasl, Roholah, (2008), Computational fluid dynamics software FLUENT, Tarah Publication.
5. Shojayi Fard, Mohamad Hasan, Norpor Hashrodi, Alireza, (2008), Introduction to Computational Fluid Dynamics, Secend Edition, Iran University of Science and Technology Publication.
6. Kalani, Ardeshir, Mahyar, Geranmehr, Hashemi, Seyed Hosein, Taher Shamsi, Ahmadi, (2010), Numerical modeling of the propagation and distribution of air pollutants and its comparison with the Gaussian plume model, Eighth International Congress on Civil Engineering.
7. Kamali Fard, Mojgan, Mokhtari Gorgani, Iman, (2004), Air pollution and lung diseases, and cardiovascular and nervous, First Conference of air pollution and its effects on health.
8. Kanani Harandi, Masoud, Fatehi Far, Esmaeil, Hamed Morshedi, Playing Simulation gaseous pollutants from industrial chimneys with regard to the surrounding buildings, Journal of Civil and Environmental Engineering, University of Tabriz, No (4), Serial 60.
9. Taheri Gharagozlo, Mohamad Javad, Vahedi Hamied, (1993), Effective height of the chimney power plants from the standpoint of environmental pollution, Seventh International Conference on Electricity.
10. Atayi, Hooshmand, Hashemi Nasab, Sadat, (2011), And analysis of models of the atmosphere in middle level of air pollution in Esfahan, Journal of Urban Studies and Planning, Second Year, No.4.
11. Yahyayi Mahmod, (2000), Effect Wind on Structures, KN Toosi University Press.
12. Wolfgang R., (1984), Turbulence Models and their Application in Hydraulic: a state-of-the art review, International Association for Hydraulic Research, Delft, p.p 27.
13. Ye Li, (1998), Numerical Evaluation of Wind-Induced Dispersion of Pollutants around Building, A Thesis in the Department of Building, Civil and Environmental Engineering, Concordia University, Montreal, Quebec, Canada.

Citation of This Article

Ali Hooshmand A. Numerical Study on the Effect of Combined Buildings on Pollution Emission with using FLUENT software. Bull. Env. Pharmacol. Life Sci., Vol 3 [8] July 2014: 17-24